



Greenspace III / Greenspace Power

GreenSpace III is your energy efficient, cost-effective LED downlight solution with a high system efficacy. In fact, you can expect up to 73% more energy savings compared to conventional compact fluorescent downlights. The GreenSpace III is the perfect retrofit solution, delivering quality lighting that is diffused and uniform. The compact, elegant design can be used across a variety of applications, including offices, shops and hotels.



Features and Benefits

- The latest LED technology delivers high system efficacy, resulting in up to 73% energy savings compared to older, traditional CFL downlights.
- 50,000 hour lifetime @L70.
- A comprehensive range provides a greater flexibility of choices.
- Improved PMMA material creates a higher diffusion rate for uniform, diffused lighting effect.
- Light efficacy of more than 90 lm/W.

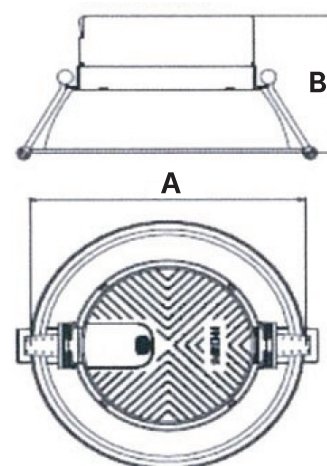

Greenspace III

Product ID	Width (mm) A	Height (mm) B	Cut-out (mm)
DN280B (White)	139	96	ø105 - 110
DN281B (White)	187	103	ø150 - 155
DN282B/DN283B (White/Aluminium)	234	117	ø200 - 205
DN280B (Aluminium)	121	94	ø105 - 110
DN281B (Aluminium)	170	103	ø150 - 155
DN280Z Adaptor Ring (White)	138		
DN281Z Adaptor Ring (White)	185		
DN282Z/DN283Z Adaptor Ring (White)	249		

Dimensions in mm

Greenspace Power

Product ID	Width (mm) A	Height (mm) B	Cut-out (mm)
DN284B 3500 lumen	234	113	150 - 155
DN284B 4500 lumen	234	117	ø150 - 155
DN285B 3500 lumen	294	158	ø200 - 205
DN285B 4500 lumen	294	163	200 - 205

Dimensions in mm